

# CHARLES A. AND MARGARET L. SCARL

P.P.N. 08-A-030-0-00-011-0 DOCUMENT NO. 2007R037167 10687 PROUTY ROAD

SITUATED IN THE TOWNSHIP OF CONCORD, COUNTY OF LAKE AND STATE OF OHIO AND KNOWN AS BEING PART OF ORIGINAL LOT NO. 36, IN TRACT NO. 4 AND PART OF ORIGINAL LOT NO. 7, IN TRACT NO. 3 WITHIN SAID TOWNSHIP, AND TOWNSHIP NO. 10 NORTH, RANGE VII WEST, IN THE CONNECTICUT WESTERN RESERVE SURVEY.

TOWNSHIP/CITY/VILLAGE: CONCORD TOWNSHIP LOT NO. 36 IN TRACT NO. 4 AND LOT NO. 7 IN TRACT NO. 3 LAKE COUNTY, OHIO	MONTH: 23RD OCTOBER	PAGE: ONE OF ONE
YEAR: 2013		
SURVEY FOR: CHARLES A. AND MARGARET L. SCARL		



**TRUE NORTH**  
ODOT VRS AND CORS GNSS NETWORK  
NAD83, NGVD88, GRS80, GEOID2012A

GRAPHIC SCALE: 1" = 20'

- DENOTES 5/8" x 30" IRON (STEEL) REBAR PIN (#5 REBAR) WITH YELLOW PLASTIC CAP BEARING "KOSIE P.S. 8167" SET
- DENOTES RIGHT-OF-WAY (R/W) CENTERLINE (C.L.)
- T.B.D. - DENOTES "TO BE DETERMINED"
- DENOTES FLOW OF WATER (RUNOFF)
- ~ DENOTES EDGE OF WOODLINE

**PROPOSED GRADE**  
EXISTING GRADE

### SILT FENCE DETAIL

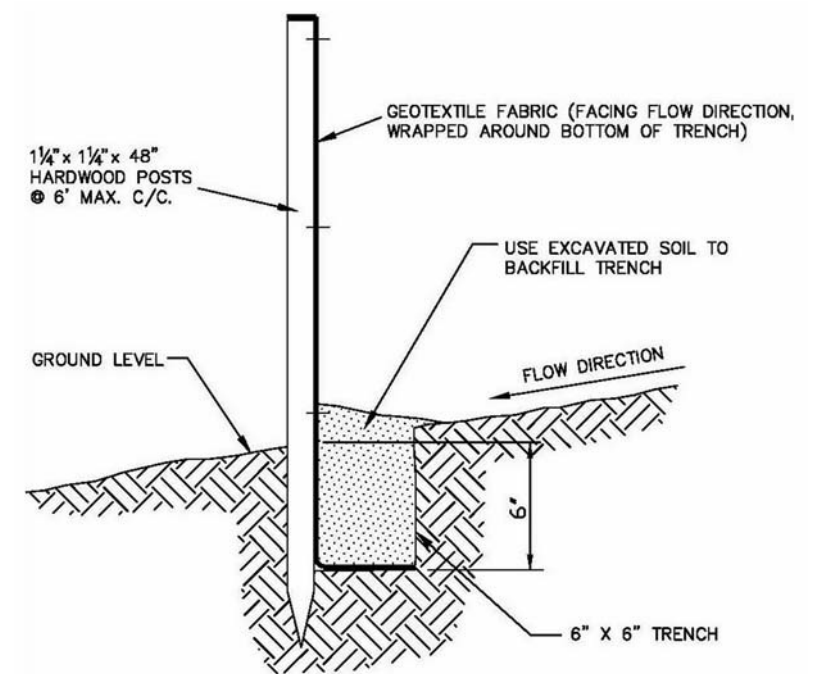

TYPICAL CROSS SECTION

### STONE ACCESS DRIVE DETAIL

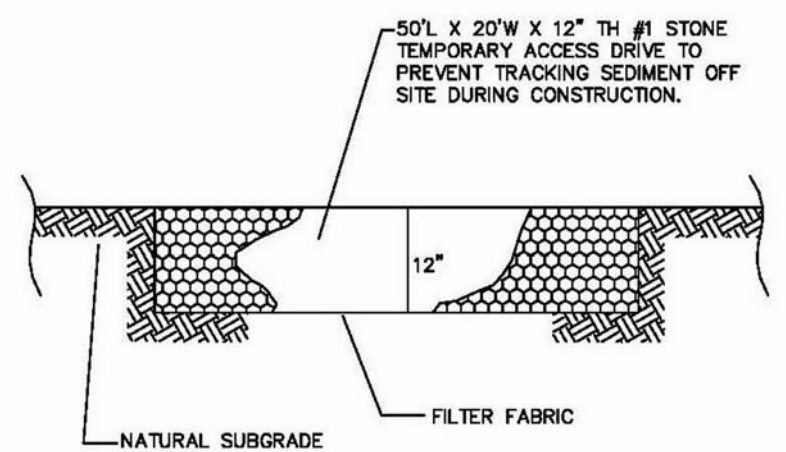

NO SCALE

### TEMP. SEEDING DETAIL

Seeding Dates	Species	Lb. / 1000sqft	Per Acre
March 1 to August 15	Oats	3	4 bushel
	Tall Fescue	1	40 lb.
	Annual Ryegrass	1	40 lb.
	Perennial Ryegrass	1	40 lb.
August 16 to November 1	Rye	1	2 bushel
	Tall Fescue	1	40 lb.
	Annual Ryegrass	1	40 lb.
	Perennial Ryegrass	1	40 lb.
November 1 to Spring Seeding	Wheat	1	40 lb.
	Tall Fescue	1	40 lb.
	Annual Ryegrass	1	40 lb.
	Perennial Ryegrass	1	40 lb.

Note: other approved seed species may be substituted.

P.P.N. 08-A-030-0-00-012-0  
WARREN AND BARBARA H. BLACKMORE  
DOCUMENT NO. 2002R038687  
PARCEL NO. 1

-NO CONCRETE TRUCK RINSING OR WASHOUT SHALL BE PERMITTED ON THIS SITE.  
-NO FUEL/LIQUID TANK STORAGE SHALL BE PERMITTED ON THIS SITE.  
-ALL VEHICLES ARE TO BE CLEANED AND MUD FREE PRIOR TO LEAVING THIS SITE. THE STREET IS TO BE KEPT CLEAN AT ALL TIMES DURING CONSTRUCTION. PROVISIONS SHOULD BE MADE FOR STREET SWEEPING / STREET CLEANING, AS NEEDED.

P.P.N. 08-A-030-0-00-011-0  
CHARLES A. AND MARGARET L. SCARL  
DOCUMENT NO. 2007R037167  
10687 PROUTY ROAD

FIN. FL. EL.: 781.5  
FIN. GAR. FL. EL.: 779.5  
TOP OF BLOCK EL.: 780.5  
FIN. BSMT. FL. EL.: 772.8  
TOP OF FOOTER: 772.5  
BOTTOM OF FOOTER EL.: 771.65

DISTURBED AREAS OF THE SITE THAT ARE TO REMAIN IDLE FOR MORE THAN TWENTY-ONE (21) DAYS SHALL BE PROPERLY SEEDED AND STRAW MULCHED WITHIN SEVEN (7) DAYS OF COMPLETION OF INITIAL GRADING. IF DISTURBED, TEMPORARY SEEDING AND MULCHING OF A THIRTY (30) FOOT STRIP OF THE ENTIRE FRONT OF THE LOT SHALL BE MAINTAINED ON THE SITE ONCE INITIAL GRADING IS COMPLETE. EROSION AND SEDIMENT CONTROLS SHALL BE INSPECTED EVERY SEVEN (7) DAYS OR WITHIN 24 HOURS OF A 0.5" OR GREATER RAINFALL EVENT. NECESSARY REPAIRS SHALL BE MADE AT THIS TIME.

P.P.N. 08-A-018-0-00-026-0  
EARNESTINE M. JONES  
DOCUMENT NO. 2004R045037  
PARCEL NO. 2  
10731 PROUTY ROAD

NOTE: ALL DOWNSPOUTS TO BE SPLASH BLOCK OR TIED INTO FOOTER DRAIN

PROPOSED FOOTER DRAIN SIZE, LOCATION, AND PUMP DETAIL T.B.D. BY INSTALLER

PROPOSED OVERHEAD ELECTRIC, CABLE, AND TELEPHONE LOCATIONS T.B.D. BY UTILITY COMPANIES

PROPOSED WATER LINE LOCATION AND SHUT OFF T.B.D. BY UTILITY COMPANY

PROPOSED GAS LINE W/ TRACER WIRE T.B.D. BY DOMINION EAST OHIO GAS CO.

50' MIN. SETBACK

TEMPORARY SEEDING/MULCHING AREA SEE DETAIL

INGRESS-EGRESS STONE ACCESS DRIVE SEE DETAIL

## PROUTY ROAD 60 FEET WIDE

**T.B.M. #99**  
BOLT ON N. SIDE OF PLATE ON HYDRANT  
EL.: 785.94

I CERTIFY TO:

CHARLES A. AND MARGARET L. SCARL

THAT I HAVE SURVEYED THESE PREMISES AND PREPARED THIS PLAT OF SURVEY IN ACCORDANCE WITH THE PROVISIONS OF CHAPTER 4733-37 OF THE OHIO REVISED CODE GOVERNING LAND SURVEYS IN THE STATE OF OHIO. THE BEARINGS SHOWN HEREON ARE BASED ON TRUE NORTH USING THE ODOT VRS AND CORS GNSS NETWORK (NAD83, NGVD88, GRS80, GEOID2012A). DISTANCES ARE BASED ON U.S. FEET WITH DECIMAL PARTS. THE ABOVE CERTIFICATION IS INTENDED ONLY TO THOSE PARTIES NAMED HEREIN, AND IS VALID ONLY WHEN ACCOMPANIED BY AN ORIGINAL SIGNATURE BELOW. THE UNDERSIGNED HAS NOT BEEN PROVIDED A TITLE EXAMINATION AND THIS SURVEY IS BASED ONLY ON THE DOCUMENTS SHOWN ON THIS PLAT OF SURVEY. NO LIABILITY IS ASSUMED FOR THE EXISTENCE OF ANY OTHER DOCUMENTS THAT MAY AFFECT THE SURVEYED PREMISES THAT WOULD BE REVEALED BY A TITLE EXAMINATION. THE UNDERSIGNED ASSUMES NO LIABILITY FOR THE USE OF UNAUTHORIZED COPIES OF THIS PLAT OF SURVEY, NOR FOR ANY USE, OR RELIANCE UPON, BY PERSONS OTHER THAN THOSE SPECIFICALLY NAMED HEREIN FOR THE INTENDED PURPOSE OF THIS SURVEY.

This plat was prepared by  
**D.B. Kosie & Associates**  
Professional Land Surveying

11040 Madison Road  
Montville, Ohio 44064  
**440.286.2131**  
Fax: 440.968.3578  
www.dbksurveys.com



ROBERT L. KOSIE, P.S.  
REGISTERED PROFESSIONAL LAND SURVEYOR  
REGISTRATION NO. 8167



## DBK PLAT NO. 710 2013